

# 2000 Model Tester

## Operating Instructions

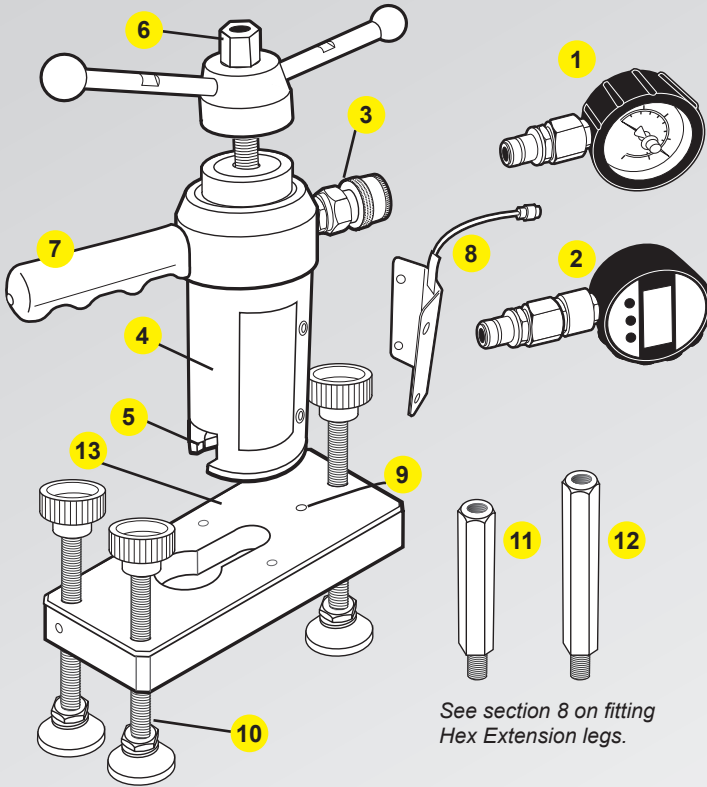

# 2000 Model Tester



See section 8 on fitting  
Hex Extension legs.

## Model 2000 Parts

1. Gauge - Analogue with QR Hydraulic Coupler
2. Gauge - Digital with QR Hydraulic Coupler (optional)
3. Quick release coupling when fitted or gauge (1 & 2)
4. Tester body with 50mm/scale indicator
5. Load jaw
6. Turning handle with integrated nut
7. Grab Handle
8. Displacement sensor (Bluetooth option)
9. Level bubble
10. Threaded Legs
11. 75mm Hexagonal Extension Legs (optional)
12. 100mm Hexagonal Extension Legs (optional)
13. Tester bridge

## TECHNICAL SPECIFICATIONS

- Pull-out load range 0-25kN/lb/f
- Weight
  - Tester only 2.2kg
  - Packaged weight 8kg (will vary)
- Stroke scale 0-50mm
- Effective stroke 50mm
- Load gauge fixed or Interchangeable
- Casing Aluminium
- Loading jaw Pivotal through 360° with Spring return
- Operating handle Standard size with integrated 22mm operating nut for confined spaces

### Load Gauges

- Ranges available: Digital: 0-30kN  
Analogue: 0-5, 0-10, 0-15, 0-20  
and 0-25kN/lb/f (5600lbf).
- Accuracy: Analogue to +/-2.5% fsd  
Digital to +/-0.5% fsd
- Indication of pull-out load
- Calibrated in kN
- Traceable UKAS calibration certificate supplied with each gauge
- Protective rubber cover (analogue only)
- Impact resistant glass
- Protection against sudden load relief (i.e. sudden failure of fixing)
- Analogue and Digital: peak hold memory
- Working Temperature:  
Analogue: -20°C to +60°C  
Digital: -30°C to +85°C

## GENERAL DESCRIPTION

The model 2000 pull-out tester is a purpose made system for testing fixings, fasteners and anchors. It consists of a mechanical screw arrangement acting through a hydraulic load cell, which measures the load applied to the fixing directly. The resulting load value is then indicated on the dial type analogue gauge or optional digital gauge.

The tester has a built in movement indicator scale 50mm to show "first movement" on the fixing prior to the test load being applied. The tester and bridge are supplied as an integral part of all the 2000 tester kit ranges.

A comprehensive range of accessories is also available, further increasing the scope of possible testing applications.

## USE OF THE TESTER AS DIRECTED

The tester is intended for use by skilled personnel with the appropriate training and knowledge of the applicable safety precautions.



**It is essential that the operating instructions are read before the tester is operated for the first time.**

**Always keep these operating instructions together with the tester.**

**Ensure that the operating instructions are with the tester when it is given to other persons.**

## CONTENTS

	<i>Page</i>
Model 2000 Parts	2
Technical Specifications	2
General description	3
Kit contents	4
<b>1. GENERAL TESTING PROCEDURE</b>	<b>5</b>
<b>2. PULLING ADAPTORS</b>	<b>8</b>
2.1 The bolt test adaptor	
Slotted button adaptors	
Threaded button adaptors	
2.2 Threaded stud adaptors	9
2.3 The insulation adaptor	
2.4 Threaded rod adaptors	10
2.5 The clevis adaptor	
<b>3. SCAFFOLD TESTER KIT</b>	<b>11</b>
<b>4. SAFETY HARNESS EYEBOLT TESTER KIT</b>	<b>14</b>
<b>5. WALL TIE TESTER KIT</b>	<b>16</b>
<b>6. MATERIAL BOND TESTER KIT</b>	<b>18</b>
<b>7. OPTIONAL LOAD SPREADING BRIDGES</b>	<b>21</b>
<b>8. FITTING HEX EXTENSION LEGS</b>	<b>21</b>
<b>9. CARE OF TESTER</b>	
9.1 Lubrication	22
9.2 Oil refilling instructions	23
9.3 Calibration	

## SAFETY RULES

- Modification of the tester, or tampering with its parts is not permissible.
- Observe the information printed in the operating instructions applicable to operation care and maintenance.
- The tester and its accessories may present hazards when used incorrectly by untrained personnel or not as directed.
- Use only the genuine Hydrajaws accessories or ancillary equipment listed in the operating instructions.

## TESTER AND ACCESSORIES

### FULL KIT CONTENT RANGE:

1. Model 2000 tester attached to 150 load spreading bridge
2. Oil bottle (Detachable gauge only)
3. Analogue load gauge(s)
4. Digital load gauge(s)
5. Button adaptors slotted set. 4.5, 5.5, 6.5, 8.5, 10.5 & 12.5mm
6. Button adaptors metric set. M4, M5, M6, M8, M10 & M12
7. Hex socket wrench set 2.5mm and spare screws
8. M12 ringbolt adaptor clevis
9. M5 threaded rod adaptor
10. M6 threaded rod adaptor
11. M8 threaded rod adaptor
12. M10 threaded rod adaptor
13. M10 threaded stud adaptor
14. M12 threaded stud adaptor
15. M16 threaded stud adaptor
16. M20 threaded stud adaptor
17. Insulation adaptor
18. Bolt tester adaptor
19. 50mm hexagon extension legs
20. 75mm hexagon extension legs
21. 100mm hexagon extension legs
22. 3mm Ball driver
23. 10mm single wrench
24. 22m ratchet spanner
25. M12 locking adaptor (inside tester)
26. Piston key
27. Carrying case with foam filler
28. Operating Instructions
29. Certificate of Calibration

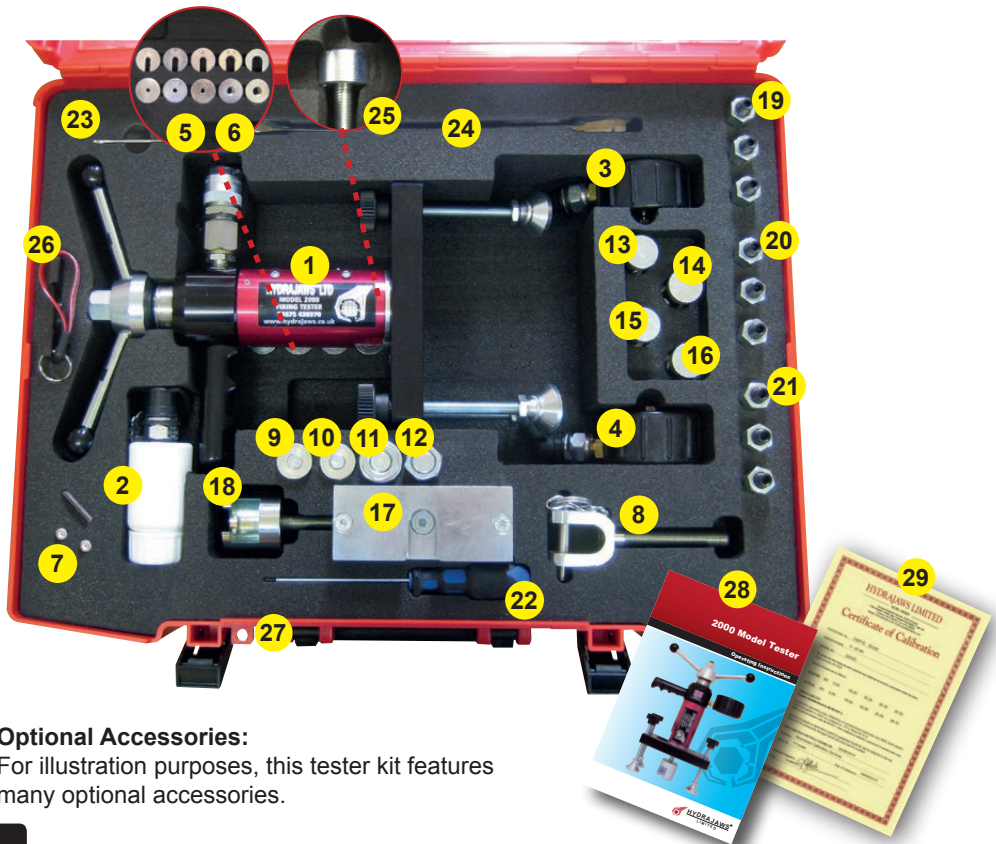

### Optional Accessories:

For illustration purposes, this tester kit features many optional accessories.

# 1. GENERAL TESTING PROCEDURE

## SETTING UP THE TESTER

1. Fit the appropriate adaptor to the tester. Example shown is a bolt tester adaptor. (For fitting of other adaptors please see individual instructions in this manual).
2. The tester is supplied with a locking adaptor fitted into the tester body. This locking adaptor can be removed for fitting of different adaptors by using the 3mm Ball Driver. When replacing back in ensure it is fully engaged into the tester body before tightening into this, until it is fully engaged, using a quarter turn for position (fig 1). Thread the bolt tester adaptor into this, until it is fully engaged, using a quarter turn for position (fig 2).
3. Make final adjustments so that the bolt tester adaptor, tester and fixing are aligned (fig 3).
4. Position the tester so that the gauge can be easily read.
5. Adjust the length of the threaded legs so that all three are in contact with the base material and the load spreading bridge is aligned and level by referring to the bubble levels on each face.

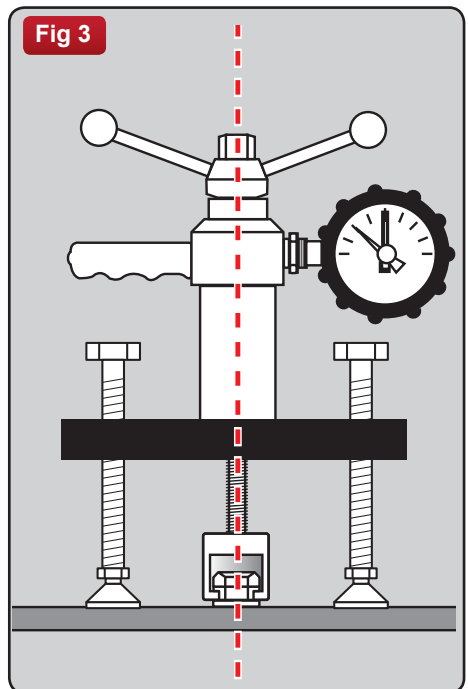
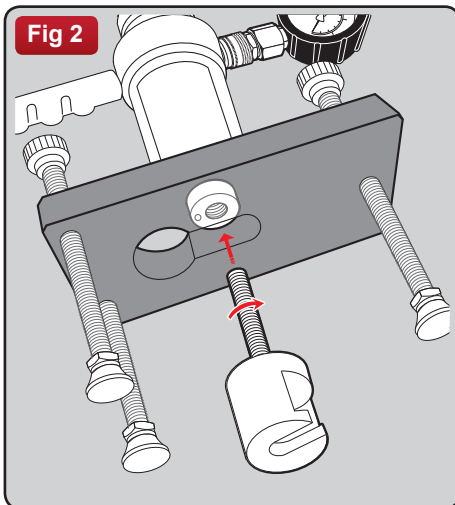
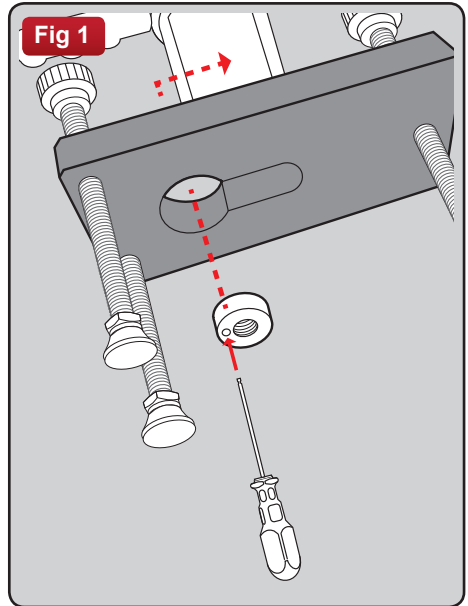

## 1. GENERAL TESTING PROCEDURE *continued..*

### TESTING PROCEDURE

- Set the red pointer on the gauge to zero - hold the tester by the grip handle and proceed to load the fastener by turning the operating handle clockwise (**fig 4**).

#### **CAUTION!**

Hold the fastener securely by the grip handle as long as the fastener is under load. When the load increases, note the reading on the displacement scale on the tester. Indication of failure of the fastener may be obtained by comparing the current reading with the original reading.

- Increase the load until the required test load is attained. Hold this load and observe any falling back of the readings which would indicate movement and possible failure of the fastener. Record the satisfactory result.
- Release the load on the fastener by turning the operating handle anti-clockwise and allowing the test jaw to return to the original position.
- Remove the tester and bolt tester adaptor.

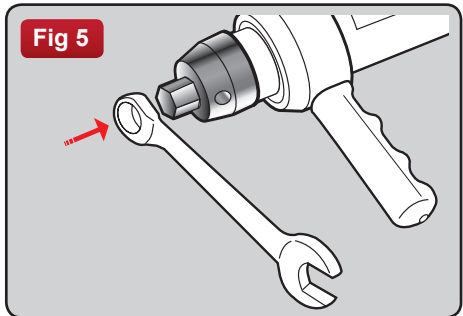
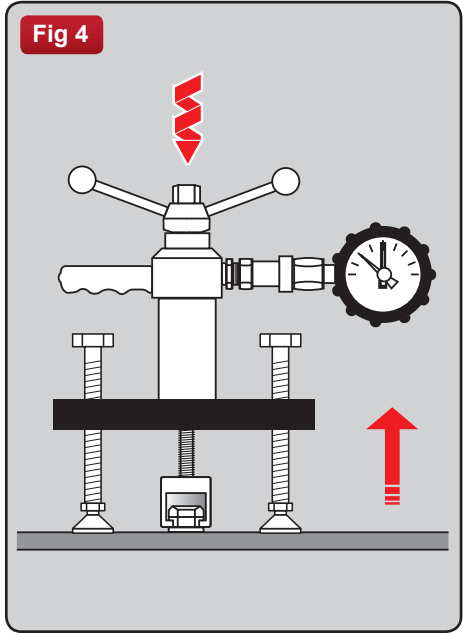

### Using the integrated nut in confined spaces

In confined spaces the integrated nut can be used with a 22mm ratchet spanner for better access in confined spaces and for easier operation (**fig 5**).

Remove the handles by unscrewing from the base using the 10mm wrench (**fig 6**). Ensure when re-attaching handles that they are tight on and secure.

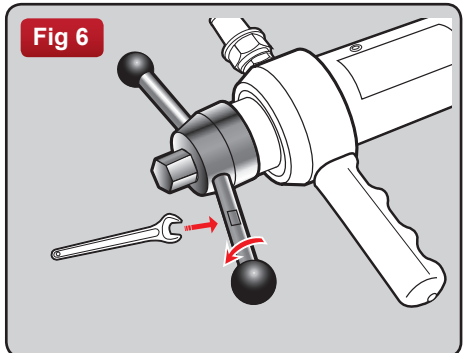

## Adjusting the handle position (fig 7)

The top part of the unit can be rotated if the handle or gauge becoming obstructed by the unit legs or other objects.

This is achieved by loosening the three grub screws (a) on the body using the allen key provided. Rotate the top until the handle and gauge are clear of obstacles and re-tighten the screws.

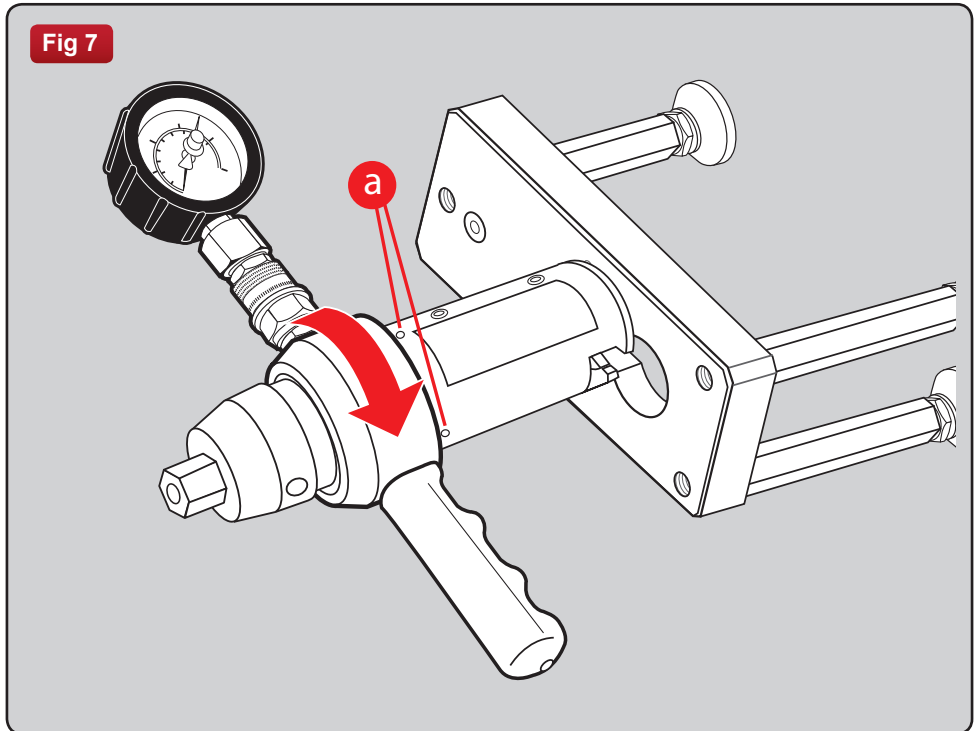

**It is recommended when testing on ceilings (inverted) and/or vertically, that a safety line is**

**attached around the tester body to a suitable solid fixing point. This will stop the tester falling and prevent injury to personnel and/or damage to test unit.**

**If no suitable fixing point is available then attach to safety harness on personnel.**

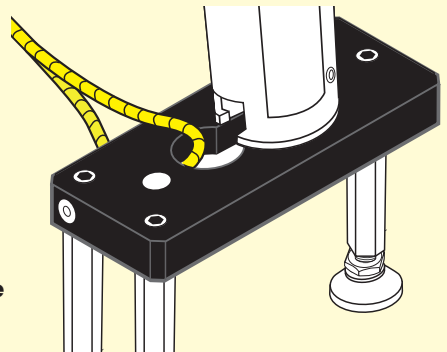

## 2. PULLING ADAPTORS

### 2.1 THE BOLT TEST ADAPTOR

#### Using the bolt test adaptor directly

For M16 nuts, (fig 8) the bolt tester adaptor (a) directly engages the nut (b) in the pulling jaw.

Mount the locking adaptor into the tester (see Section 1 General testing procedure). Then thread the bolt tester adaptor into the tester body (fig 9).

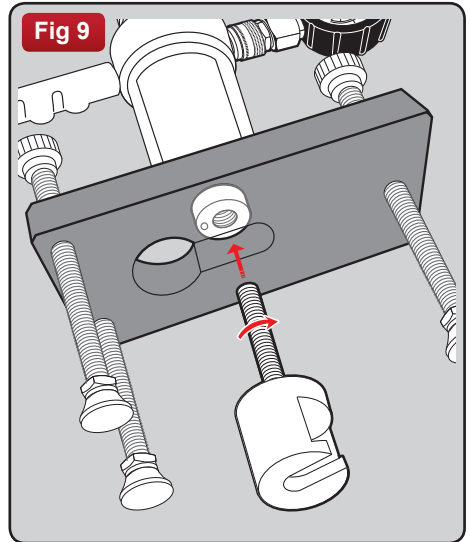
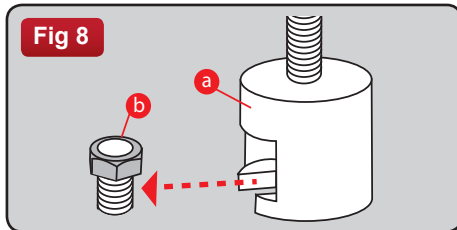

#### Using the bolt test adaptor with the slotted button adaptor

For testing fixings where a connection is made underneath the head of the fixing or anchor the slotted button adaptor is used.

Mount the locking adaptor into the tester (see Section 1 General testing procedure). Then thread the bolt tester adaptor into the tester body (fig 9).

The slotted button adaptor (a) slots into the bolt tester adaptor (b) and engages the fixing (c) (fig 10).

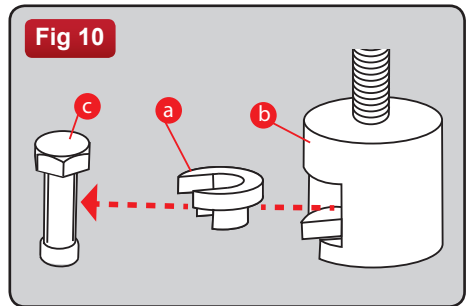

#### Using the bolt test adaptor with the threaded button adaptor

For testing threaded fixings the threaded button adaptor is used.

Mount the locking adaptor into the tester (see Section 1 General testing procedure). Then thread the bolt tester adaptor into the tester body (fig 9).

The threaded button adaptor (a) threads on to the fixing (c) and then slots into the bolt tester adaptor (b) (fig 11). Ensure the button adaptor has at least 2 complete thread turns on the fixing and is secure.

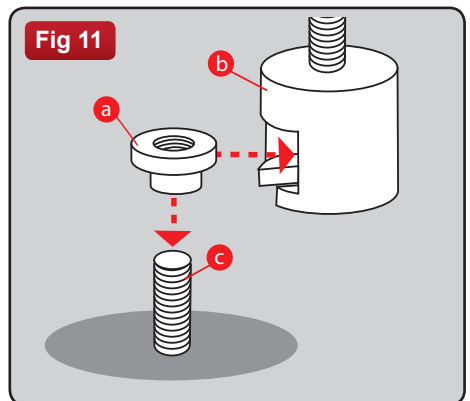



## 2.2 M10, M12, M16 AND M20 THREADED STUD ADAPTORS

Suitable for testing sleeve and stud anchors.

(fig 12) After the anchor has been set in accordance with the manufacturers recommendations, a suitable threaded rod (a) is screwed into the anchor and the adaptor (b) then fitted. The length of the threaded rod to be screwed into the anchor must be at least equal to the diameter of the anchor.

Remove the locking adaptor if fitted (see Section 1 General testing procedure). When the adaptor is securely fitted to the anchor thread position, place the tester over the adaptor, passing the head through the hole in the bridge and engage it in the pulling jaw of the tester (fig 13). Level the load spreading bridge with the adjustable legs before commencing the application of the load.

Note: (fig 14) To use the optional M30 HD Threaded stud adaptor, first attach 45mm M20 thread piece (c) into adaptor (e) and attach to the fixing. Then thread the M20 Adaptor (d) and proceed as above. Hexagonal leg extensions may be required.

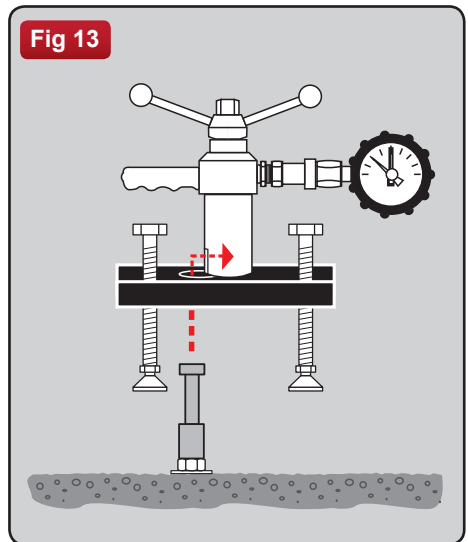
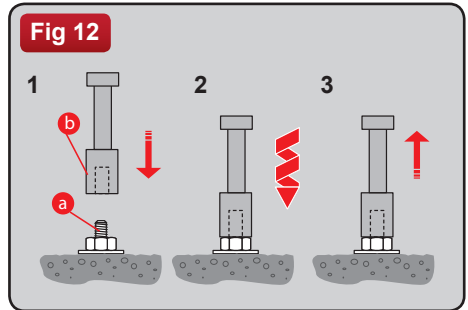
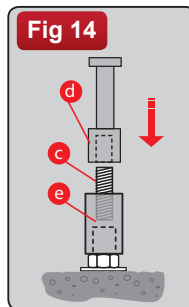

## 2.3 THE INSULATION ADAPTOR

Remove the insulation around the fastener.

Mount the locking adaptor into the tester (see Section 1 General testing procedure). Thread the insulation adaptor into the locking adaptor fully then back off until horizontal.

By holding the tester, slide the head of the insulation fastener (a) between the two plates with the stem of the fixing resting in the slot in the lower plate (b) and adjust the legs on the load spreading bridge to suit the base material. Ensure that the pull-out force acts along the axis of the fixing being tested (fig 15).

Hexagonal leg extensions may be required to reach an insulation fastener that is raised.

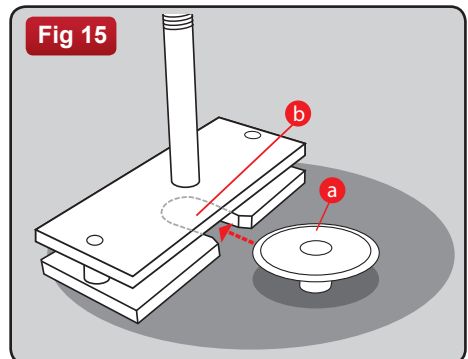

## 2.4 M5, M6, M8 AND M10 THREADED ROD ADAPTORS

The M5 and M6 threaded rod adaptors are equipped with an external M12 thread for use in conjunction with the M12 threaded button adaptor. They are used primarily for testing remedial wall ties. The M8 and M10 threaded rod adaptors are equipped with an M16 external thread and the M16 nut fitted with connects to the pulling slot in the tester or bolt tester adaptor.

Connect the threaded rod adaptor complete with the M12 button adaptor to the thread on the fixing (fig 16).

Remove the locking adaptor if fitted (see Section 1 General testing procedure). Adjust the length of the bridge legs and the height of the button adaptor/nut so that the adaptor can pass through the hole in the bridge and engage it in the pulling jaw of the tester (fig 17).

Level the load spreading bridge with the adjustable legs before commencing the application of the load.

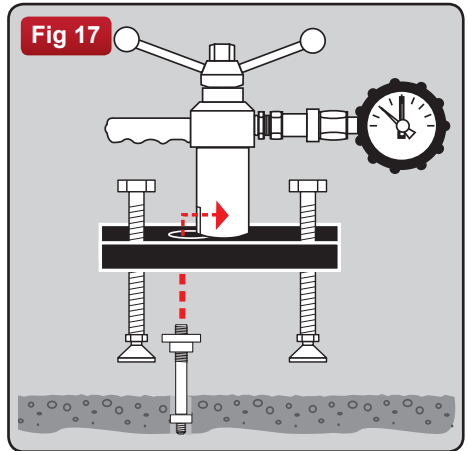
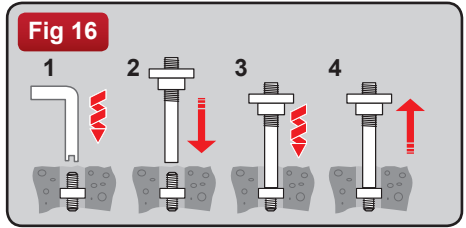

## 2.5 THE CLEVIS ADAPTOR

For testing ringbolts the Clevis adaptor is used.

Mount the locking adaptor into the tester (see Section 1 General testing procedure). Then thread the clevis adaptor into the tester body until it is fully engaged, using a quarter turn for positioning (fig 18).

Remove crosspin from the clevis adaptor and offer the tester and bridge to engage eye of the anchor in the clevis. Some adjustment will be required on the swivel feet, so that this fit is achieved. Push clevis pin through the clevis and eyebolt, ensuring that the ball on the pin clicks into place, having passed through the second fork (fig 19). Once fitted securely commence testing (see Section 1 General testing procedure).

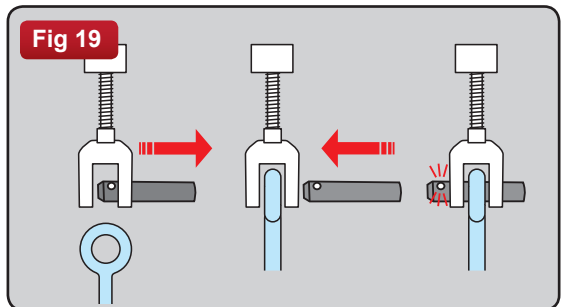
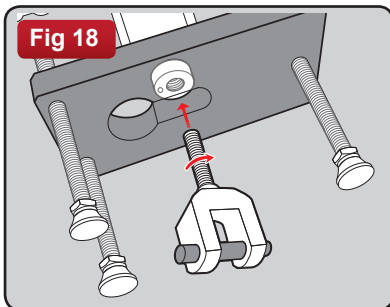

### 3. SCAFFOLD TESTER KIT

The Hydrajaws Test meter is part of a purpose made system for testing fixings and measures the load supplied. The Scaffold Tester Kit has accessories designed to test Scaffold Anchors and Ringbolts to the requirements of the guidance note TG4-04 issued by National Access and Scaffolding Confederation (NASC) and the Construction Fixings Association (CFA).

The Tester is factory assembled with the bolt tester adaptor screwed into the M12 locking adaptor located in the Tester jaw, and the three 100mm hexagon legs with swivel feet fixed to the 150 load spreading bridge. Further adjustment available in the foot (20mm).

#### **KIT CONTENTS:**

- 2000 model Medium Duty Tester with fixed Gauge to 20kN\*
- 150mm Load Spreading Bridge
- 100mm Hex Extension legs (3)
- Turning handle with integrated 22mm operating nut
- M16 Hex Setscrew
- Bolt Tester Adaptor
- M12 Ringbolt Adaptor Clevis
- M12 Locking Adaptor
- Calibration Certificate
- Padded Carrying Case

*\* Some models have removable gauge and coupler system*

---

### TESTING OF M16 DROP IN SCAFFOLD TIE ANCHORS

Fit the M16 hexagon setscrew to the anchor, ensuring at least two complete turns for ample thread engagement. Offer Tester with bridge to the hexagon head of the setscrew and engage head in bolt tester adaptor jaw. Make adjustment on each swivel foot by unscrewing from the hexagon extension legs so that each foot is resting on the material around the anchor and the bridge is square and level.

Check that the black gauge pointer is resting on zero and set the red maximum indicator pointer to zero by turning the knob on the gauge glass anti-clockwise.

Commence the test by turning the operating handle on the Tester clockwise and observe the gauge as the load on the anchor is increasing. Continue applying the load until the proof test load is reached (kN) with the black gauge pointer. Stop applying the load and observe if the black pointer falls back, leaving the red pointer at the maximum load achieved. If the fall back on the black pointer is minimal, apply the load again until both pointers are at the test load required and leave the test load in place for approximately 10 seconds.

Should the black pointer not reach the maximum test load requirement, or the operating handle has to be turned to maintain the load, it is certain that the anchor will have failed the test.

### TESTING OF EYE TYPE ANCHORS

Unscrew the bolt tester adaptor from the M12 locking adaptor in the Tester jaw and replace it with the ringbolt adaptor clevis. Ensure that at least 2 complete clockwise turns are made to safely engage the threads. Remove crosspin from the clevis and offer the Tester and bridge to engage eye of the anchor in the clevis. Some adjustment will be required on the swivel feet, so that this fit is achieved, push clevis pin through the clevis and eyebolt, ensuring that the ball on the pin clicks into place, having passed through the second fork. Commence the test as described for drop in anchors.

*Note: Longer Scaffold Eyebolts used in timber frame construction can be tested. But extra long extension legs are required – not supplied in standard kit.*

The new NASC/CFA Guidance Note TG4:04\* “Anchorage Systems for Scaffolding” sets out requirements for PRELIMINARY TESTS of scaffold anchors (to check the suitability and allowable loads of an anchor type in a particular base material) and PROOF TESTS (sample tests to check that anchors have been installed correctly – to be carried out on all jobs).

The new Proof Load testing requirement is for a tensile test of 1.5 x the design load. The Hydrajaws Scaffold Tester Kit will test all of these types to a maximum tensile load of 20kN. TG4:04 also describes six types of anchor most commonly used for anchoring scaffold ties. The Hydrajaws Scaffold Tester Kit will test all of these types to a maximum tensile load of 20kN.

\* TG4:11 can be downloaded free of charge from the CFA website at [www.fixingscfa.co.uk](http://www.fixingscfa.co.uk)

**Fig 20** Test rig arrangements for:

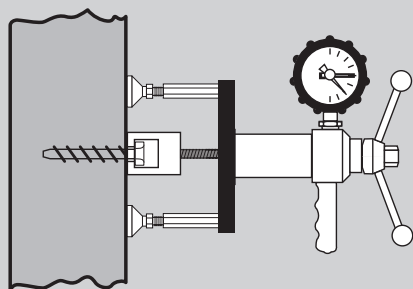

Hex headed bolts, including self tapping concrete screws

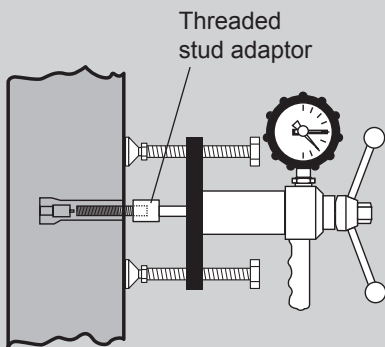

Socket anchors using slave bolts. e.g. for ringbolt

**Fig 21** Test rig arrangements for:

Standard ringbolt

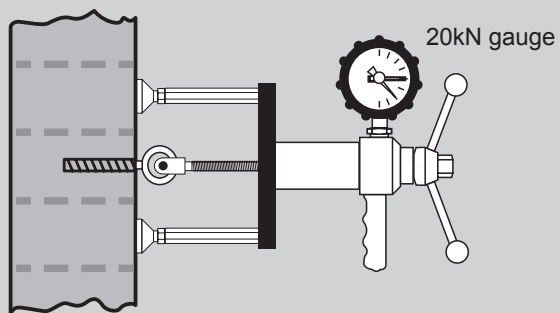

Scaffold ringbolt

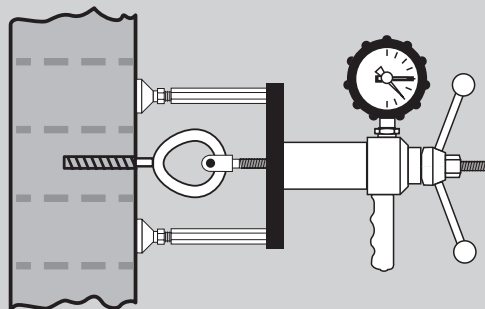

Drop-in anchors (concrete only)

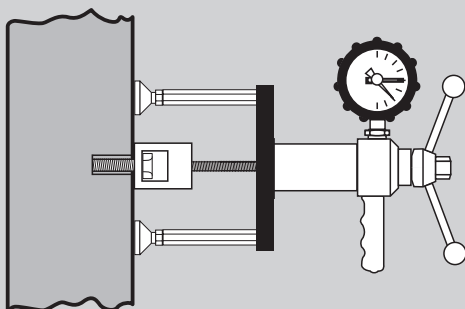

## 4. SAFETY HARNESS EYEBOLT TESTER KIT

For testing Safety Harness Eyebolts to the requirements of BS5845 and BS EN795 Protection Against Falling From A Height, Anchor Devices - Requirement for Testing and BS 7883: 2005 BS 788: 2005 code of practice for Design, Selection, Installation, Use and Maintenance of Anchor Devices conforming to BS En 795. The kit may also be used for testing Ladder Restraint Hooks and most Ringbolts in concrete or masonry.

The Tester is factory assembled with the ringbolt adaptor screwed into the M12 locking adaptor located in the Tester jaw and the 150 load spreading bridge with the three 75mm hexagon legs with swivel feet with 25mm of fine adjustment.

### KIT CONTENTS:

- 2000 model Medium Duty Tester with fixed Gauge to 15kN\*
- 150mm Load Spreading Bridge
- 75mm Hex Extension Legs (3)
- M12 Ringbolt Adaptor with Locking Adaptor
- Turning handle with integrated operating 22mm nut
- Calibration Certificate
- Padded Carrying Case

*\* Some models have removable gauge and coupler system*

### TESTING A SAFETY HARNESS EYEBOLT (fig 22)

Place the bridge over the eyebolt to be tested. Locate the clevis on the eyebolt and fit the cross pin through the clevis and eyebolt, ensuring that the ball on the pin clicks into place, having passed through the second fork (**see section 2.5 The Clevis Adaptor**).

Adjust the swivel feet by unscrewing from the hexagon leg, so that each foot is resting on the material around the eyebolt and the bridge is square and level. Fit a protection plate between wall and bridge feet if necessary, to protect soft decorative finishes.

Check that the black gauge pointer is resting on zero and set the red maximum indicator pointer to zero, by turning the knob on the gauge window anticlockwise.

Commence the test by turning the operating handle on the tester clockwise and observe the gauge as the load on the eyebolt is increasing. Continue applying the load until the proof test load of 6kN is reached with the black gauge pointer. Stop applying the load and observe if the black pointer falls back, leaving only the red pointer at the maximum load achieved.

If the fall back is minimal, apply the load again until both pointers are at the proof test load and the structural anchorage should then sustain the force for a minimum of 15 seconds.

### TESTING A LADDER RESTRAINT HOOK (fig 23)

Follow the same setting up procedure as for Safety Harness Eyebolt test, and apply the load gradually until the required proof load of 2.5kN is reached or failure occurs. Observe if the hook withdraws from the structure or the test load cannot be achieved. This would be considered a failure and must be taken out of service

**Fig 22**

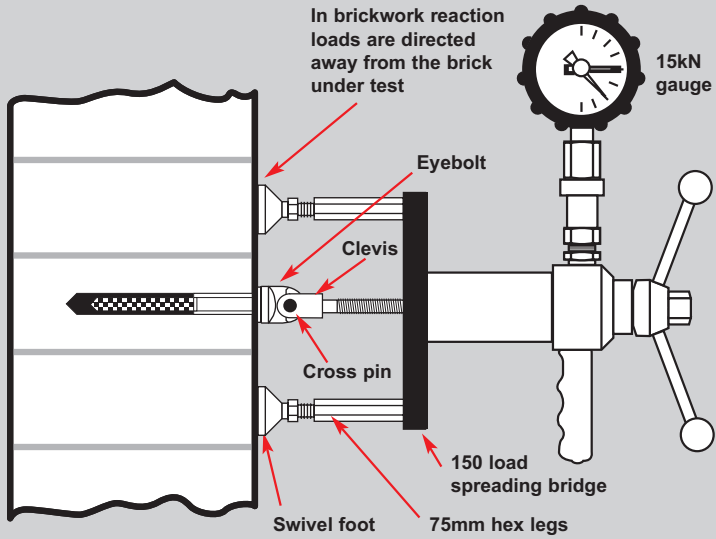

**Fig 23**

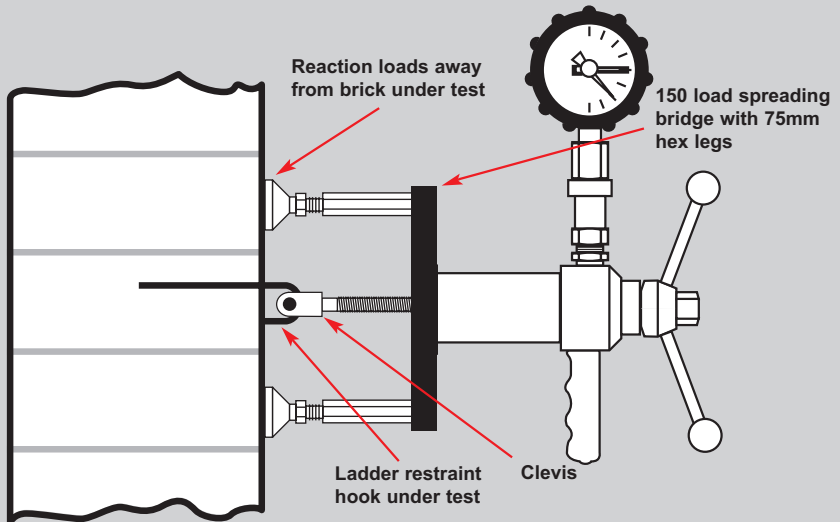

## 5. WALL TIE TESTER KIT

### SITE TESTING OF WALL TIES

The purpose of carrying out site tests on wall ties is either as part of a site survey to investigate the suitability of the base material for the use of a particular tie or during the installation of the ties to verify the quality of the installation.

#### KIT CONTENTS:

- 2000 model Medium Duty Tester with fixed Gauge to 5kN\*
- Wall Tie Spacer Bridge
- M5 & M6 Wall Tie Adaptors
- Calibration Certificate
- Padded Carrying Case

\* Some models have removable gauge and coupler system

In accordance with the BBA recommendation on Remedial wall ties it is required that the first 3 ties in a building should be tested followed by 1 tie in every 20 installed. BRE Digest 401 'Replacing wall ties' specifies that the inner end of the first 20 ties installed on a contract should be all proof tested and that a reducing rate of testing is required for the remaining ties, for 21 to 250 ties 10% should be tested, for 251 to 1000 ties 5% should be tested and for more than 1000 ties 2.5% should be tested.

### LOAD PROCEDURE

Generally the loading procedure for testing wall ties is the same for both ends of wall ties regardless of whether they are mechanical and chemical fixings, so the loading procedures which follow. Connect the wall tie adaptor complete with the M12 threaded button adaptor to the end of the wall tie, taking care not to tighten the outer leaf expansion nut (fig 24).

With the test meter securely attached to the Bridge, adjusting the length of the legs on the loading bridge and the position of the button adaptor if necessary, pass the adaptors through the keyhole slot in the loading bridge and ensure that the button adaptor is centred in the test meter (fig 25).

Use the levelling screws on the bridge to take up the slack in the system and to ensure that the test meter is axially aligned with the wall tie under test.



**DO NOT LOAD THE TIE WITH THE LEVELLING SCREWS.**

Fig 24

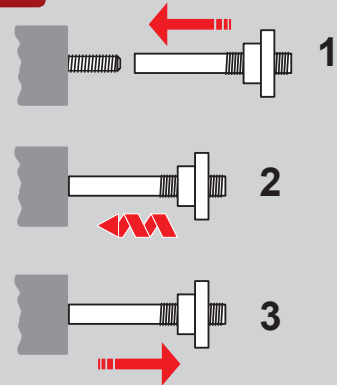

For inset wall ties - ensure width of hole (a) is wide enough to accommodate the wall tie adaptor and is set deep enough (b).

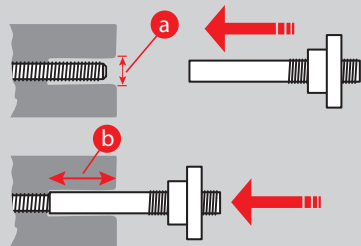



Position the test meter so that the gauge is in the most convenient place to read it. Set the red pointer at zero. Whilst holding onto the handle on the test meter body, turn the loading handle clockwise to increase the load on the anchor.

*Note: Do not let go of the tester before the load has been removed.*

When the load starts to increase note the scale reading on the displacement scale behind the gauge on the test meter body. Keep increasing the load until the required load is achieved (for test

load please consult manufacturers recommendation). Some indication of the displacement of the Tie can be obtained by comparing the reading from the displacement scaled while the fixing is under load with the first reading noted. To release the load rotate the handle anti-clockwise and push down until the original position is resumed. Lift the test meter off the stud adaptor and unscrew the adaptor and studding.

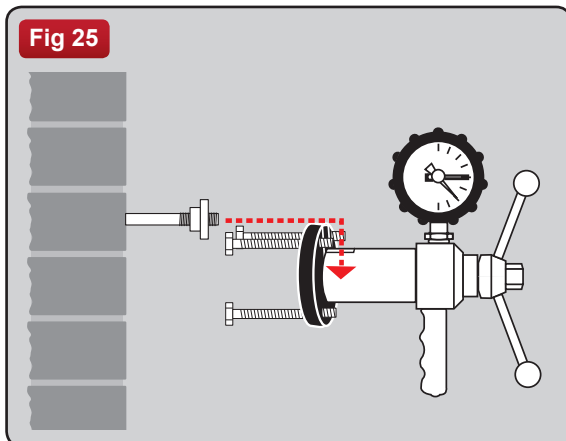

## PROCEDURE, INNER LEAF

Install the tie into the inner leaf in accordance with the method statement appropriate to the wall tie being used. If appropriate leave the resin mortar to cure for at least the recommended curing time. Load the tie in accordance with the procedure given above. If the displacement of the tie is judged to be excessive then the quality of the fix into the base material is suspect. Remove the testing assembly and complete the installation of the tie in accordance with the appropriate method statement.

## PROCEDURE, OUTER LEAF, MECHANICAL CONNECTIONS

It is not possible to test the outer leaf in isolation on a normally installed tie.

## OPTIONAL ADAPTORS

Optional adaptors are available for non-threaded ties. For example, the Helifix wall tie (pictured on right) has a special adaptor to enable testing.

**Please contact us for information on our range of special adaptors.**



*Note: A sample of the tie may be required to confirm the right adaptor is supplied.*

## NOW AVAILABLE: WALL TIE TESTER KIT MK 2

The Hydrajaws Wall Tie Tester Kit Mk2 is used for testing all types of remedial wall tie to meet the requirements of DD140. It is used with appropriate adaptor and mounts direct to tester.

The Mk2 Kit comes with M5 and M6 threaded rod adaptors and a selection of adaptors are available to suit a wide range of wall ties.



## 6. MATERIAL BOND TESTER KIT

The bonding strengths of a wide and varied range of materials including concrete, screeds, repair mortars, epoxy resin coatings, laminates, plastics, paints and enamels may be accurately determined using the Hydrajaws Material Bond Tester.

Adequate direct tensile strength or bonding strength between two layers is important if repairs to concrete structures or additional overlays and screeding on existing concrete is to be structurally sound.

The pull-off test as a means of projecting the compressive strength of concrete and other materials involves bonding a circular steel disc to the surface by means of an epoxy resin adhesive.

A controlled tensile force is then applied to the disc, and as the strength of the bond is greater than that of the material under stress it will eventually fail in tension. From the area of the disc and the force applied at failure it is possible to calculate a nominal tensile strength for the material.

### KIT CONTENTS:

- 2000 model Medium Duty Tester with fixed Gauge to 25kN\*
  - Bond test stool with adjustable legs
  - 10x50mm & 10x 75mm steel bond discs
  - Bond test plug
  - Calibration Certificate
  - Padded Carrying Case
- (Can accommodate 20x50 & 20x75 discs)*

Equipment that may be required in addition to the standard kit contents:

- Adhesive
- Spatula
- Bondline spacers -  
i.e. ballotini (glass spheres)
- Diamond-coated core drill

*\* Some models have removable gauge and coupler system.*

## ON SITE PULL-OFF METHOD

### Procedure for preparing samples for pull-off testing:

1. Clean the steel dollies (degrease and grit blast unless otherwise stated). This will help to prevent interfacial failures at the dolly interface.
2. For concrete substrates drill through the repair system with diamond core drill at  $(90\pm)^\circ$  to the surface into the test surface by ~5mm or more.

This ensures a consistent bond area and will therefore help reduce variations in the test results.

3. Clean the substrate test surface as recommended by the manufacturer.
4. Mix the adhesive as recommended by the adhesive supplier and add 1% by weight of ballotini (usually 0.5mm unless stated otherwise).

Adding ballotini will reduce alignment errors and therefore help reduce variations in the test results.

5. Apply adhesive to steel dolly.

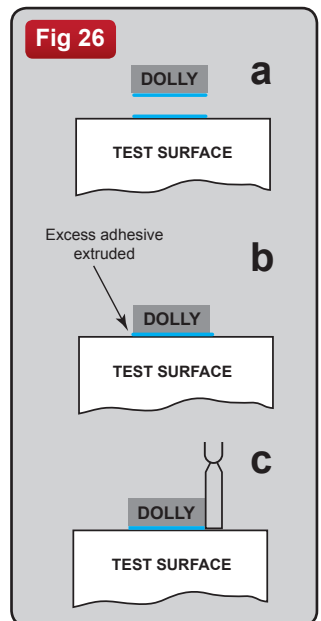

6. Apply adhesive to substrate test surface (**fig 26a**). This ensures the adhesive wets out both surfaces and helps prevent interfacial failures.
7. Press the steel dolly into the substrate test surface with a firm pressure (**fig 26b**) DO NOT 'seat' the dolly by twisting it into position. If the dolly is twisted into position it will increase the likelihood of interfacial failures.
8. Remove excess adhesive from around the edge of the dolly without disturbing its position (**fig 26c**). This ensures a consistent bond area and will therefore help reduce variations in the test results. If working on a vertical or overhead surface, ensure the dollies are held firmly in position until the adhesive has cured.
9. Connect centering plug to disc using the 8mm thread and hand tighten until bottom is flush with top disc (**fig 27a**).
10. Lower load stool centre hole over centering plug and adjust the 3 screws until top of plug is flush and level with top of stool. It is essential that this levelling is carried out carefully to ensure a square and smooth pull through the stool. The load applied to the centre of the dolly should be at an angle of  $90^{\circ} \pm 1^{\circ}$  (**fig 27b**).
11. Slide Tester over adaptor on top of plug and fit 22mm socket and ratchet to the operating nut (**fig 28**). Secure equipment so that it does not move during testing. This will cause excess misalignment which will reduce pull-off strengths.
12. Operate ratchet in a clockwise direction until required loading is obtained or bonding breaks. Record test temperature, failure load and failure mode (**fig 29**) (Record mixed failure modes in percentages of bond area, i.e. 90% substrate failure, 10% cohesive failure). Maximum loading achieved will be shown by red indicator pointer. Use this reading to calculate the bond strength Mpa from the chart on page 20.

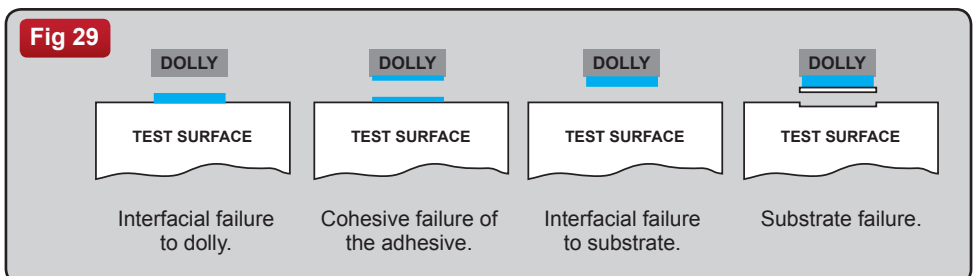
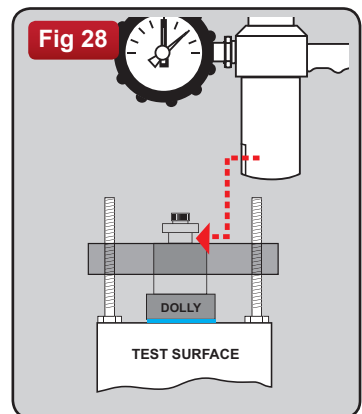
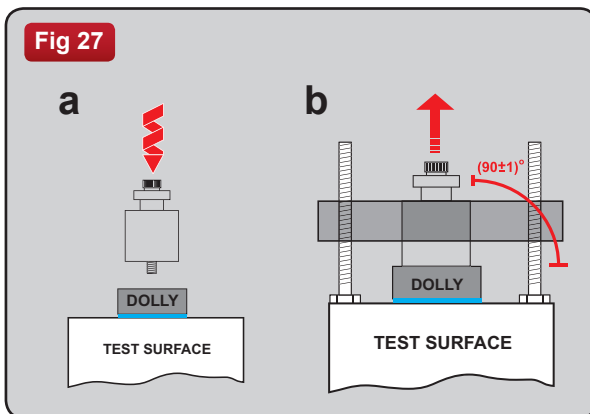

## MATERIAL BOND TESTER KIT *continued..*

### IMPORTANT! A low reading will be obtained if:

- The pull-off tester is misaligned and not perpendicular to the specimen
- The specimen is misaligned and not perpendicular to the pull-off tester
- The bondline is not of uniform thickness (0.5mm)
- A sudden or erratic loading is applied.

*Note: This information is for guidance only. Please also refer to adhesive manufacturer's data and safety sheets.*

Replacement discs available in both sizes from stock.

### ACTUAL PULL FORCE READ DIRECT FROM GAUGE

50mm dia Disc Area 1964mm <sup>2</sup> Bond Strength MPA	Actual Pull Force kN	75mm dia Disc Area 4418mm <sup>2</sup> Bond Strength Mpa
0.51	1.00	0.23
1.01	2.00	0.45
1.53	3.00	0.68
2.03	4.00	0.90
2.55	5.00	1.13
3.05	6.00	1.36
3.56	7.00	1.59
4.07	8.00	1.81
4.58	9.00	2.04
5.09	10.00	2.26
5.06	11.00	2.49
6.11	12.00	2.72
6.62	13.00	2.94
7.13	14.00	3.16
7.63	15.00	3.40
8.15	16.00	3.62
8.66	17.00	3.85
9.16	18.00	4.07
9.67	19.00	4.30
10.20	20.00	4.52
10.70	21.00	4.98
11.71	23.00	5.20
12.22	24.00	5.43
12.73	25.00	5.65

Mpa (Mega Pascals) = N/mm squared

Mpa = Actual Pull Force divided by Area of Disc x 1000

## 7. OPTIONAL LOAD SPREADING BRIDGES

Hydrajaws offer three optional load spreading bridges, a pyramid stool with threaded legs and a 270mm or 600mm wider span bridge with telescopic legs. These are designed to attach easily to the Hydrajaws Model 2000 Tester.

To install, first remove any existing load spreading bridge by removing the two positioning screws using the 3mm ball driver. Use the same screws to secure the tester to the optional bridge.

The 270mm and 600mm load spreading bridges can be installed so the tester is operated in two different positions as illustrated. The legs are fully adjustable to suit the testing application.

A thread adaptor coupler is also supplied to extend the accessory in use. The Pyramid stool is supplied with an extended bolt test adaptor.



## 8. FITTING HEX EXTENSION LEGS (Regular)

1. First unscrew the foot from the existing leg (**fig 30**) (This may be tight and require a spanner).
2. Screw the foot to the extension leg (**fig 31**). Ensure it is fully engaged.
3. Screw the extension leg onto the exposed thread on the bridge (**fig 32**).
4. Ensure the extension leg is screwed on all the way up to the bridge and is flush against it.
5. Repeat for the other two legs.

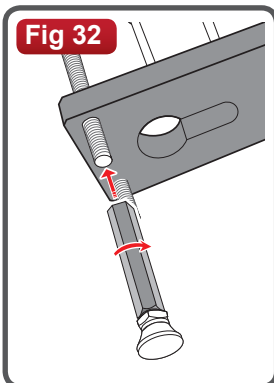
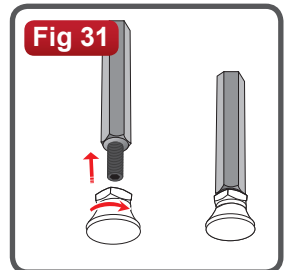
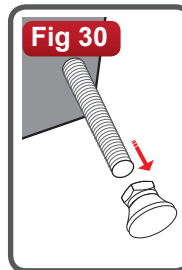

### Eyebolt / Scaffold Hex Extension Legs Arrangement



These screw into the bridge directly (**fig 33**).

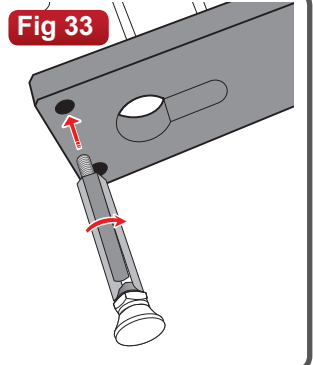

## 9. CARE OF TESTER

### 9.1 LUBRICATION

#### Lubrication of rod

This is required periodically depending on usage.

Unscrew and remove operating handle. Take care to avoid moving the washer and bearing below. Grease surfaces and threads before re-assembly (**fig 34**).

#### Oil refilling

Connecting and disconnecting Gauges from the Tester body will eventually use up the spare oil capacity and will not allow the tester plunger to travel it's full stroke or give an accurate reading on the Gauge.

Eventually the plunger will stop at approx. 3mm from the edge and indicate that oil is too low (**fig 35**).

(To refill oil see **9.2 oil refilling instructions**).

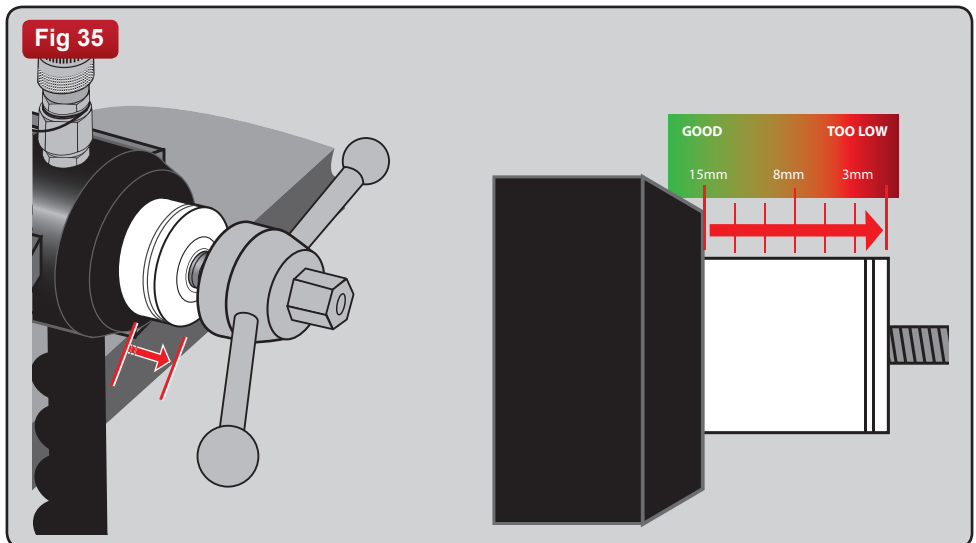
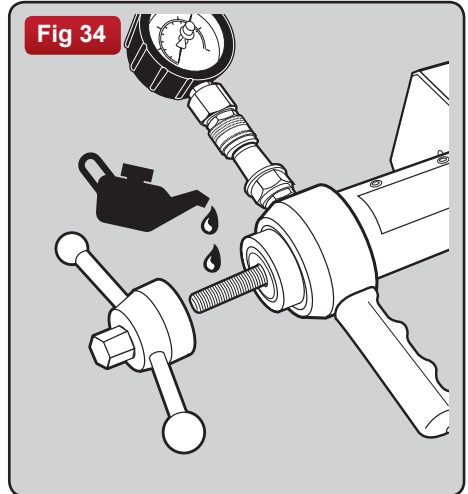

## 9.2 OIL REFILLING INSTRUCTIONS

*NOTE: A tester with a fixed gauge cannot be filled with oil by the operator.*

1. Remove the bridge and all accessories.
2. Secure the tester (e.g. in a vice or other suitable holding device if on-site) with the coupler in the vertical position.
3. Connect the oil bottle via the quick release coupler.
4. Loosen bottle cap (**fig 36**).
5. Turn the handle anti-clockwise a few turns then using the piston key provided insert this into the groove on the piston. Ensure the piston key outer slot is nearer the piston body (**fig 37**).
6. Force any air out of the system by pushing the piston in fully then pull on the piston key and handle until 10mm away from the inside of the slot. This will draw oil from the bottle (**fig 38**).
7. Push the piston back in fully, pull out again and repeat until all the air bubbles are expelled into the bottle, the oil is replenished, and piston is 10mm from face of the body.
8. Remove oil bottle.

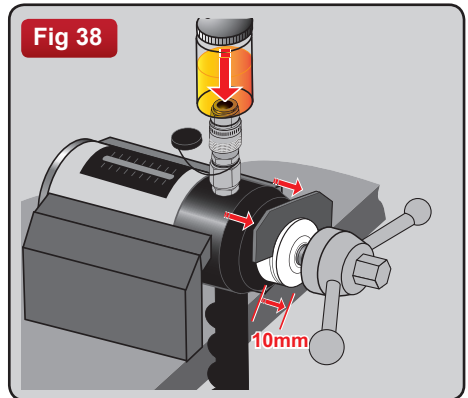
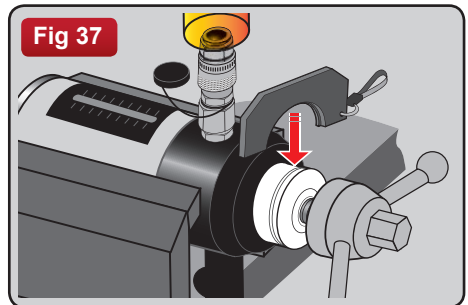
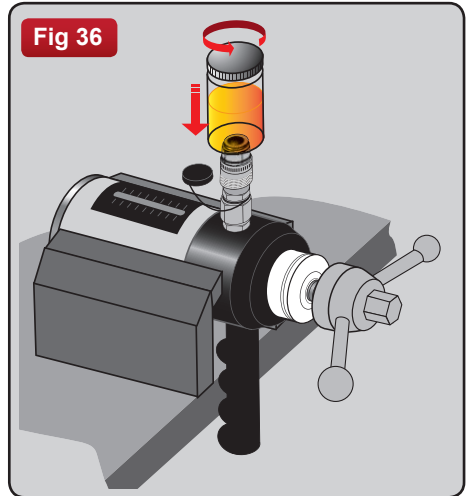

**Ensure not to pull the piston out further than 15mm.**



Recommended oil:  
**Light Mineral DTE Type**

## 9.3 CALIBRATION

From the date of purchase, your tester is calibrated for one year. After this time, the tester should be returned for calibration. Testers with Bluetooth Digital will receive a reminder message on their digital display, one month from date of renewal.

**FOR MORE INFORMATION  
ON HYDRAJAWS AND A  
FULL RANGE OF TESTING  
APPLICATIONS PLEASE VISIT  
THE WEBSITE AT:  
WWW.HYDRAJAWS.CO.UK**



**HYDRAJAWS<sup>®</sup>**  
**LIMITED**

20/21 The Courtyard  
Gorse Lane  
Coleshill  
Birmingham  
B46 1JA

Tel: +44 (0)1675 430 370  
Fax: +44 (0)1675 465 950

email: [tester@hydrajaws.co.uk](mailto:tester@hydrajaws.co.uk)  
[www.hydrajaws.co.uk](http://www.hydrajaws.co.uk)